

Probe System for Single-Channel Testing Rotating Probe 6.481.01-1xxx



Figure 1: Rotating Probe 6.481

Characteristics

- low cost industrial probe system for eddy current flaw detection
- designed for continuous work
- high throughput rate thanks to high rotation speed ($n_{max}=15.000 \text{ min}^{-1}$)
- simple system integration thanks to compact housing and low mass ($m=1 \text{ kg}$)
- maintenance-free drive through brush-free DC servo motor
- high precision true running of probes rotor by double bearing
- contactless signal transmission by rotating inductive transmitter (including clearance channel)
- synchronization pulse in 60° steps
- test frequency range 100 kHz .. 1 MHz
- specially adapted probes available for different applications

Applications

- stationary application for non-destructive flaw testing of mass-produced parts, e.g. in automotive and supplying industry
- direct integration into the production line
- application in customer-specific test stations
- suitable test electronics are STATOGRAPH S, STATOGRAPH CS, STATOGRAPH ECM, for more information about these systems see table below

Designation	Type Number	Order Number
STATOGRAPH S-System	6.420	135 774 3
STATOGRAPH ECM	6.421	103 583 5
STATOGRAPH CS	6.425	139 873 3

Mode of operation

The eddy current probe element, consisting of excitation winding, measuring winding and clearance winding, executes a circular trace above the test specimens surface. By different arrangement of the probe element inside the probes rotating axis it is possible to test flat as well as curved surfaces like the inner surface of drill holes, radii, etc.

Two different versions are available:

- Rotating Probe T (transversal) with the probe element mounted on its front end side for testing of flat surfaces
- Rotating Probe R (radial) with the probe element mounted sidewise for testing drill holes and radii

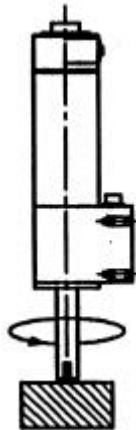

Figure 2: Rotating Probe T (transversal) with the probe element mounted on its front end side for testing of flat surfaces.

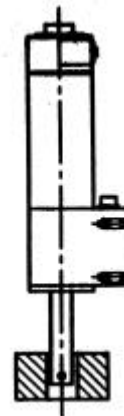

Figure 3: Rotating Probe R (radial) with the probe element mounted sidewise for testing drill holes and radii.

The rotating probe is positioned close to the test specimens surface and rotates at high speed. In order to test the entire surface either the test piece can be moved past the rotating probe if the probe system is mounted stationary or the probe (which is mounted on a slide for instance) can be moved past the test surface if the test piece is fixed in test position.

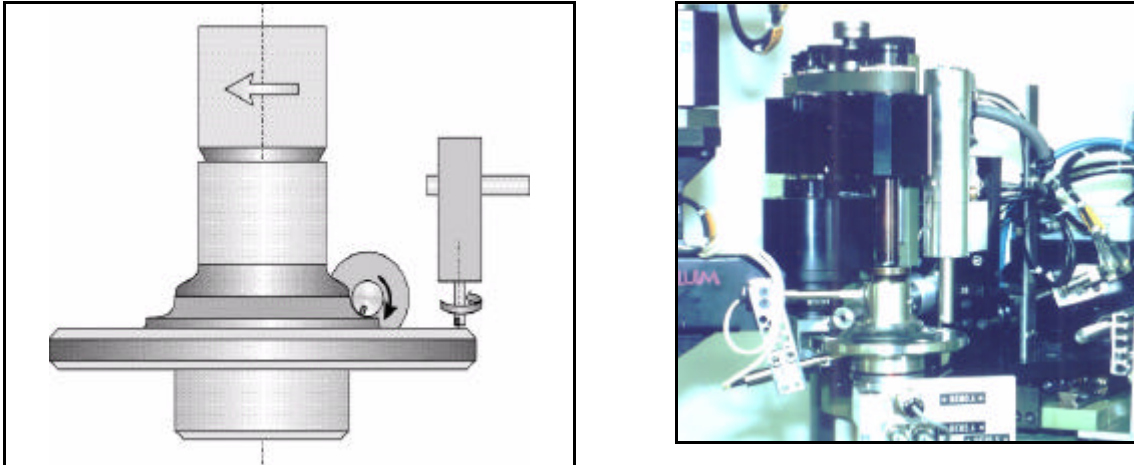

Figure 4: Example of a combined application of the Rotating Probe in wheel hub testing. Testing the flat surface for longitudinal and transversal defects by Rotating Probe T. Testing the radius for transversal defects by Rotating Probe R.

Construction

The principal connection of the Rotating Probe 6.481 to various FOERSTER test systems is shown in Figure 5.

Rotating Probe 6.481

Currently the following versions are available, see table below. Customized versions with other dimensions for length and diameter of the rotating shaft can be realized on request.

Designation	Type Number Order Number	Effective Diameter	Shaft Diameter	Probe Element
Rotating Probe (T) Nom. Size 10 mm, Length 60 mm	6.481.01-1600 148 303 0	Ø=10 mm	Ø=14 mm	Micro plate probe element 6.231.02-7102, track width 1,5 mm
Rotating Probe (T) Nom. Size 10 mm, Length 60 mm	6.481.01-1601 126 993 3	Ø=10 mm	Ø=14 mm	Plate probe element D,AK 6.231- 7101, track width 2,5 mm, clearance wind- ing
Rotating Probe (T) Nom. Size 30 mm, Length 60 mm	6.481.01-1602 153 204 9	Ø=30 mm	Ø=34/19 mm	Micro plate probe element 6.231.02-7102, track width 1,5 mm
Rotating Probe (R) Nom. Size 11 mm, Length 80 mm	6.481.01-1650 116 723 5		Ø=11 mm	Micro plate probe element 6.231.02-7102, track width 1,5 mm
Rotating Probe (R) Nom. Size 10 mm, Length 30 mm	6.481.01-1651 128 447 9		Ø=10 mm	Plate probe element D,AK 6.231- 7101, track width 2,5 mm, clearance winding
Rotating Probe (R) Nom. Size 19 mm, Length 80 mm	6.481.01-1660 119 644 8		Ø=19 mm	Micro plate probe element 6.231.02-7102, track width 1,5 mm
Rotating Probe (T) Nom. Size 15 mm, Length 60 mm	6.481.01-1710 126 712 4	Ø=15 mm	Ø=19 mm	Micro plate probe element 6.231.02-7102, track width 1,5 mm

Rotating Probe Controller

For controlling the functions of the Rotating Probe a controller is necessary. There are two different versions available:

Designation	Type Number	Order Number	Application
Rotating Probe Controller	6.481.01-1001	126 938 0	simple version with power switch, motor switch and control lights (power, motor, error); connecting socket for synchronization-cable (rot. sync.) to the test electronics
Rotating Probe Controller	6.481.01-1011	145 999 6	extended version with additional connecting socket for control cable to transmit the following information to/from the test electronics: rot. sync., masking, error condition, motor on/off

Motor Cable

To connect the Rotating Probe to the Rotating Probe Controller a motor cable is necessary. A **maximum length of 5 m** must not be exceeded. The motor cable 8.404.01-1001-61 has a length of 4 m. On the side of the rotating probe it can be extended by the **Highly Flexible Motor Cable 1 m 8.404.01-1001-64** in case of mounting the Rotating Probe on a slide.

Rotating Probe Cable 1 m

For direct connection of the Rotating Probe to a STATOGRAPH ECM in the case that the distance from rotating probe to test electronics is less than 1 m. In the other case this cable serves to connect the Rotating Probe to the Adapter, Cable Adaptation, or Line Driver (depending on the application, refer to Figure 5). **This cable cannot be extended**, i.e. the distance from Rotating Probe to either test electronics, Adapter, Cable Adaptation or Line Driver may be 1 m at maximum.

Adapter

For connection of the Rotating Probe to a **STATOGRAPH S/CS** test electronics. Includes driver electronics for the field winding and pre-amplifier for the measuring and clearance windings. Depending on the installation conditions one of the following versions can be used:

- the **Adapter 6.420.26-9712** will be connected directly to the Rotating Probe using the Rotating Probe Cable 6.481.01-9901 (cable length of 1 m can **not** be extended).
- for longer distances (more than 1 m) between Rotating Probe and Adapter the Line Driver 6.421.01-9704 is required. In this case the **Adapter 6.420.21-9718** is to be used.

Cable Adaptation

For connecting the Rotating Probe to the **STATOGRAPH ECM**, when the distance between Rotating Probe and test electronics is longer than 1 m. Connection to the Rotating Probe via Rotating Probe Cable; connection to the test electronics via Coil Cable (various lengths available); maximum distance between Rotating Probe and Cable Adaptation 1 m; distance between Cable Adaptation and STATOGRAPH ECM up to 100 m.

Line Driver

The Line Driver is only necessary in exceptional cases, e.g. when the mounting situation does not allow to install the Adapter or the Cable Adaptation at a distance of maximum 1 m from the Rotating Probe.

Possible Combinations for Connection

The following combinations to connect a Rotating Probe are possible.

STATOGRAPH ECM

Line Driver	Cable Adaptation	Application
no	no	very short distance (at maximum 1 m) between Rotating Probe and test electronics
no	yes	the normal case; distance between Rotating Probe and Cable Adaptation at maximum 1 m; distance between Cable Adaptation and test electronics up to 100 m
yes	yes	exceptional case; necessary only if limited space does not allow to mount the Cable Adaptation close to the Rotating Probe

It is not possible to operate the Line Driver without using the Cable Adaptation.

STATOGRAPH S/CS

Line Driver	Adapter	Application
no	6.420.26-9712	the normal case; distance between Rotating Probe and Adapter at maximum 1 m; distance between Adapter and test electronics up to 100 m
yes	6.420.21-9718	exceptional case; necessary only if limited space does not allow to mount the Cable Adaptation close to the Rotating Probe

Coil Cable

Serves to connect the Line Driver to the Cable Adaptation or to connect the Cable Adaptation to the STATOGRAPH ECM. The available cable lengths are summarized in the following table.

Designation	Type Number	Order Number
Coil Cable 3 m	2.899.51-1110 M3	140 793 7
Coil Cable 5 m	2.899.51-1110 M5	149 743 0
Coil Cable 20 m	2.899.51-1110 M20	140 801 1
Coil Cable 40 m	2.899.51-1110 M40	149 849 5
Coil Cable 100 m	2.899.51-1110 M100	149 744 8

Synchronization Cable ECM

For transmission of the signal Rot.Sync. to the STATOGRAPH ECM to allow for a rotation-synchronized display of the measuring signal on an oscilloscope.

Control Cable ECM

For transmission of the signals Rot.Sync. and masking signal to the STATOGRAPH ECM. Requires the extended version of Rotating Probe Controller 6.481.01-1011.

Control Cable

For connecting the Adapter 6.420.26-9712 or 6.420.21-9718 to the STATOGRAPH S/CS the control cable is necessary.

Test Cable

For connecting the Adapter 6.420.26-9712 or 6.420.21-9718 to the STATOGRAPH S/CS the test cable is necessary.

Synchronization Cable

When using the simple version of Rotating Probe Controller 6.481.01-1001 in connection with the STATOGRAPH S/CS the Synchronization Cable 6.421.01-9903 is mandatory to connect the Adapter 6.420.26-9712 or 6.420.21-9718.

Control Cable M

When using the extended version of Rotating Probe Controllers 6.481.01-1011 in connection with the STATOGRAPH S/CS the Control Cable M 6.410.01-9916 serves to transmit the extended functions (Rot.Sync., masking, error condition, motor on/off); in this case the Synchronization Cable 6.421.01-9903 is not needed; for driving these extended functions a modified version of STATOGRAPH S/CS is required.

Technical Data

Rotating Probe

testing method	DIN 54 140 eddy current
dimensions	see Figure 6
mass	approx. 1,0 kg
protection class	IP 53
permitted operating temperature	+5°C ... +40°C
maximum rotating speed	15.000 min ⁻¹

Rotating Probe Controller

dimensions (L x W x H)	approx. 400 x 230 x 110 mm ³
mass	approx. 6,5 kg
protection class	IP 53
permitted power supply	230 V~ / 50 Hz
nominal power	300 VA
permitted operating temperature	+5°C ... +40°C

Adapter

dimensions	approx. 230 x 200 x 110 mm ³
mass	approx. 3,5 kg
protection class	IP 53
permitted operating temperature	+5°C ... +40°C

Cable Adaptation

dimensions (L x B x H)	approx. 175 x 80 x 60 mm ³
mass	approx. 0,7 kg
protection class	IP 53
permitted operating temperature	+5°C ... +40°C

Line Driver

dimensions	approx. 80 x 75 x 57 mm ³
mass	approx. 0,5 kg
protection class	IP 53
permitted operating temperature	+5°C ... +40°C

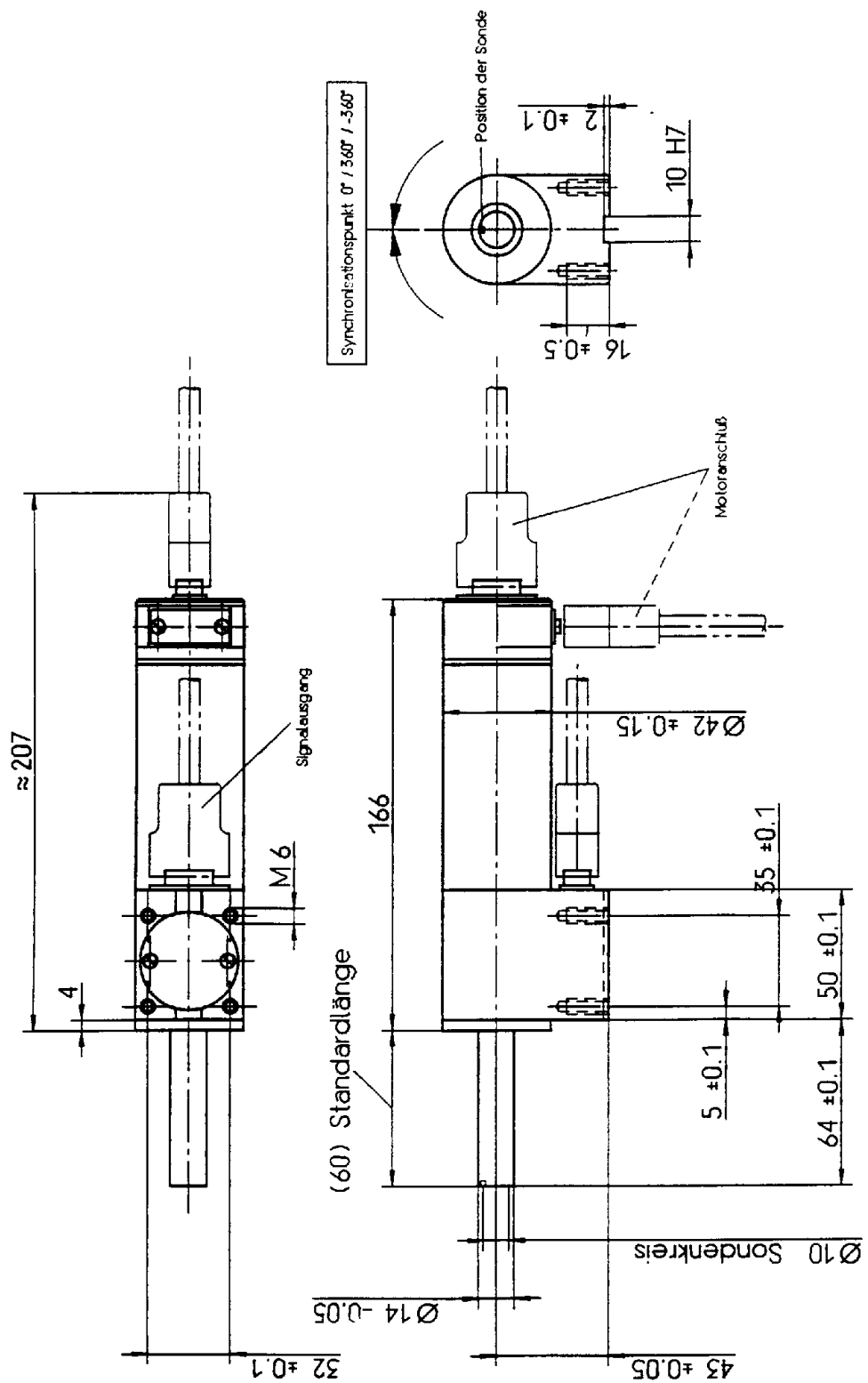

Figure 6: Dimensions of the Rotating Probe 6.481.01-1600 in its standard version. Because of different shaft dimensions the other versions can vary in their dimensions.

Product Information

Leaflets

Title	Order Number
Automatic wheel hub crack tester 9.251.01	126 945 3

Ordering Instructions

Standard Functional Sets

Rotating Probe for STATOGRAPH S/CS **6.481.80** **158 535 5**

consisting of:

Rotating Probe, see standard components	6.481.01-1xxx	
Motor Cable 4 m	8.404.01-1001-61	124 382 9
Rotating Probe Controller	6.481.01-1001	126 938 0
Rotating Probe Cable 1 m	6.481.01-9901	126 941 0
Adapter, 1-channel StaRo S	6.420.26-9712	159 343 9
Synchronization Cable 1 m	6.481.01-9903	145 930 9
Control Cable 10 m	6.410.01-9912	137 147 9
Test Cable 10 m	6.410.01-9911	136 478 2

Rotating Probe for STATOGRAPH ECM **6.481.81** **158 536 3**

consisting of:

Rotating Probe, see standard components	6.481.01-1xxx	
Motor Cable 4 m	8.404.01-1001-61	124 382 9
Rotating Probe Controller	6.481.01-1001	126 938 0
Rotating Probe Cable 1 m	6.481.01-9901	126 941 0
Cable Adaptation	6.421.01-9703	126 939 9
Synchronization Cable ECM 5 m	6.481.01-9902	145 915 5
Coil Cable 3 m	2.899.51-1110 M3	140 793 7

Standard Components

Rotating Probe, Nom. Size 10 L=60 (T)	6.481.01-1600	148 303 0
Rotating Probe, Nom. Size 10 L=60 (T)	6.481.01-1601	126 993 3
Rotating Probe, Nom. Size 15 L=60 (T)	6.481.01-1710	126 712 4
Rotating Probe, Nom. Size 26 L=60 (T)	6.481.01-1602	153 204 9
Rotating Probe, Nom. Size 10 L=30 (R)	6.481.01-1651	128 447 9
Rotating Probe, Nom. Size 11 L=80 (R)	6.481.01-1650	116 723 5
Rotating Probe, Nom. Size 19 L=80 (R)	6.481.01-1660	119 644 8
Rotating Probe Controller	6.481.01-1001	126 938 0
Rotating Probe Controller	6.481.01-1011	145 999 6
Adapter	6.420.26-9712	159 343 9
Adapter	6.420.21-9718	149 745 6
Cable Adaptation	6.421.01-9703	126 939 9
Line Driver	6.421.01-9704	126 942 9

Should you have any special problems please contact:

INSTITUT DR. FOERSTER

Joseph-von-Fraunhofer-Straße 15
D-44227 Dortmund
Phone: +49 (231) 975049-0
Fax: +49 (231) 975049-8
www.foerstergroup.de
ct@foerstergroup.de



or one of our agencies abroad	Order No.	130 094 6
Information and illustration may	Edition	09/00
be subject to change	Author	Dr. Sievers

Motor Cable 4 m	8.404.01-1001-61	124 382 9
Motor Cable flexible 1 m	8.404.01-1001-64	152 671 5
Rotating Probe Cable 1 m	6.481.01-9901	126 941 0
Control Cable M	6.410.01-9916	124 035 8
Synchronization Cable 1 m	6.481.01-9903	145 930 9
Control Cable ECM 5 m	6.481.01-9904	149 606 9
Synchronization Cable ECM 5 m	6.481.01-9902	145 915 5
Control Cable 3 m	6.410.01-9912 M3	101 535 4
Control Cable 5 m	6.410.01-9912 M5	121 488 8
Control Cable 7 m	6.410.01-9912 M7	101 247 9
Control Cable 10 m	6.410.01-9912	137 147 9
Control Cable 15 m	6.410.01-9912 M15	146 075 7
Control Cable 18 m	6.410.01-9912 M18	141 827 0
Control Cable 20 m	6.410.01-9912 M20	148 775 2
Control Cable 22 m	6.410.01-9912 M22	149 934 3
Control Cable 25 m	6.410.01-9912 M25	148 776 0
Control Cable 30 m	6.410.01-9912 M30	147 556 8
Test Cable 3 m	6.410.01-9911 M3	101 534 6
Test Cable 5 m	6.410.01-9911 M5	121 477 2
Test Cable 7 m	6.410.01-9911 M7	101 246 0
Test Cable 10 m	6.410.01-9911	136 478 2
Test Cable 15 m	6.410.01-9911 M15	146 074 9
Test Cable 20 m	6.410.01-9911 M20	148 773 6
Test Cable 25 m	6.410.01-9911 M25	148 774 4
Test Cable 30 m	6.410.01-9911 M30	147 555 0
Coil Cable 3m	2.899.25-1103 M3	140 793 7
Coil Cable 5m	2.899.25-1103 M5	149 743 0
Coil Cable 20m	2.899.25-1103 M20	140 801 1
Coil Cable 40m	2.899.25-1103 M40	149 849 5
Coil Cable 100m	2.899.25-1103 M100	149 744 8